

SOLENOID VALVES

4707 Massachusetts Ave. - P.O. Box 18128
 Indianapolis, Indiana 46218-0128
 Ph: 1-800-63 GOULD Fx: (317) 547-5234
 Web: <http://www.gouldvalve.com>
 E-mail: gouldvalve@gouldvalve.com

1/4", 3/8", & 1/2" NPT

TYPES B Series

2-WAY • CAST BRONZE BODIES • VELVETROL® INTERNAL PISTON PILOT OPERATED SOLENOID VALVES • NORMALLY CLOSED OR NORMALLY OPEN FULL PORT • MANUAL OPEN • ADJUSTABLE CLOSING SPEED



- ★ FOR: GENERAL SERVICE-AIR-INERT GASES-WATER-OIL-STEAM
- ★ PRESSURES: 5 PSI DIFFERENTIAL MINIMUM TO 1200 PSI MAXIMUM
- ★ TEMPERATURE: -40°F. MIN TO 450°F MAX. FLUID
- ★ MOUNTING: INSTALL IN HORIZONTAL LINE WITH COIL UPRIGHT AND ON TOP

SIZES 1/4", 3/8", & 1/2" NPT FULL PORT		
★ SERVICE RATINGS	Pricing, Service & Electrical Ratings shown in the List Price Schedule. Valves will be furnished for 5-150 PSI and 120 VAC Unless Otherwise Specified.	
NORMALLY CLOSED--		--NORMALLY OPEN
TYPE B	GENERAL SERVICE AIR-WATER-OIL-INERT GASES 5-150 PSI, 300°F. Max. Fluid, Class F Coil	TYPE BR
TYPE BS	GENERAL SERVICE AIR-WATER-OIL-INERT GASES 10-400 PSI, (10-300 Normally Open) 300°F. Max. Fluid, Class F Coil	TYPE BR
TYPE BST	LIQUID SERVICE ONLY 10-700 PSI, 300°F. Max. Fluid, Class F Coil	n/a
TYPE BHP	LIQUID SERVICE ONLY 20-1200 PSI, 300°F. Max. Fluid, Class F Coil	n/a
ADD L	PROVIDES ADJUSTMENT TO CONTROL FLOWRATE	ADD L
ADD -1	HIGH TEMP. (CLASS N) COILS - FLUID TEMP. TO 450°F. STEAM to 200 PSI.	ADD -1
ADD -2	EXPLOSION PROOF COIL HOUSING - CLASS I GROUP D, CLASS II GROUP E, F, G. NEMA 7	ADD -2
ADD -3B, -3EP -3T, -3V	LEAKPROOF PILOT SEAT: -3B (BUNA), -3EP ETHYLENE- PROPYLENE, -3T (TEFLON®) PTFE, -3V (VITON®) FLUOROCARBON	ADD -3B, -3EP -3T, -3V
ADD -24	WATER TIGHT COIL HOUSING - NEMA 4	ADD -24
ADD -25	DUST TIGHT COIL HOUSING - NEMA 5	ADD -25
ADD -57	MANUAL RESET/SAFETY SHUT-OFF, NO VOLTAGE RELEASE	ADD -57

★ **CONSTRUCTION:**

CLASS F & N COILS are Waterproof, Fungusproof, Molded of Filled Polyester with 18" Leads.
 BODIES are Sand Cast in Bronze rated 1200 psi, with 303 SS ADJUSTMENT STEMS.
 BONNET ASSEMBLIES are 304 SS TUBES silver soldered to Brass BONNET and TUBE PLUG.
 PISTON ASSEMBLIES are Brass with Filled Teflon® PISTON RINGS, Stainless Steel EXPANDERS, and Buna, EP, Fluorocarbon Or Virgin Teflon® SEAT DISCS. PISTON SPRINGS are 316 or 302 SS.
 PILOT ASSEMBLIES are 416 SS ARMATURE with a 316 SS PILOT POINT and 316 SS PINS.

★ **SPECIALS:**

Teflon® Coated Pistons & other Special Assemblies Available. Non-Standard Coils are Available with Voltage, Wattage, and Lead Wire Length to your specifications. Consult Factory.

★ **TERMS AND CONDITIONS OF SALE:** See the List Price Schedule.

PERFORMANCE, ORDERING AND INSTALLATION GUIDE

ORDERING DATA--SPECIFY PIPE SIZE, TYPE, FLUID, OPERATING PRESSURE, TEMPERATURE RANGE, ELECTRICAL SPECIFICATIONS, BACK PRESSURE (IF ANY).

FLOW CHARACTERISTICS--SEE FLOW CURVES IN BULLETIN 5-FL, OR C_v'S BELOW AND IN BULLETIN CP-1.

OPERATION--PISTON PILOT OPERATED. MINIMUM PRESSURE DROP OF 5 PSI (ΔP) IS REQUIRED ACROSS VALVE FOR OPERATION. TURN STEM MARKED "ADJ" CLOCKWISE TO INCREASE CLOSING TIME. TURN STEM MARKED "MAN OPN" COUNTER CLOCKWISE TO OPEN THE VALVE MANUALLY. TURN CLOCKWISE UNTIL SEATED TO CLOSE VALVE FOR NORMAL OPERATION.

MOUNTING--MOUNT IN HORIZONTAL LINE WITH COIL VERTICAL AND ON TOP. INSTALL 40 MESH STRAINER (NOT LARGER) AHEAD OF VALVE. CHECK FOR PROPER COIL VOLTAGE. MAKE SURE THAT THE FLOW ARROW ON VALVE BODY IS POINTING IN THE DIRECTION OF FLOW.

FLOW CONTROL--(Types BL & BSTL)--TURN FLOW CONTROL STEM (In Bottom Plug) CLOCKWISE to DECREASE FLOW, COUNTER CLOCKWISE TO INCREASE FLOW.

SERVICING--SOLENOID VALVES SHOULD BE FREQUENTLY CHECKED FOR OPERATION, CLEANLINESS, & INTERNAL WEAR - REPAIR KITS ARE FACTORY AVAILABLE --GIVE SIZE, TYPE, SERIAL NUMBER OR OPERATING DATA (VOLTAGE, PRESSURE, ETC.)

#	Part Description	Valve Type	1/4" • 3/8" • 1/2"
1	N. C. Bonnet Assembly	B	P30A
	N. O. Bonnet Assembly	BR	P30R
	N. C. Bonnet Assembly	B-2	P30XP
	N. O. Bonnet Assembly	BR-2	P30XPR
2	Piston Spring	ALL	37-14
	HP Piston Spring	ALL HP's	37-4
3	Seat Screw	ALL	31-4x
4	Piston Assembly	ALL	P29-1x
5	Piston Only	ALL	29
6	Seat Ring	ALL	34
7	Bottom Plug	ALL	35
	Flow Ctrl Btm Plug	ALL BL's	35-1
8	Packing Retainer	ALL	69
9	Packing	ALL	16
10	Packing Gland	ALL	15
11	Adjustment Stem	ALL	2-1
12	N.C. Pilot Assembly	B	P21-1
	N.O. Pilot Assembly	BR	P32R-2
	N.C. XP Pilot Assembly	B-2	P25-1
	N.O. XP Pilot Assembly	BR-2	P32R-1
13	Piston Ring & Expander	ALL	P57
14	Seat Disc	ALL	36-12x
15	Disc Screw	ALL	33
16	Body	ALL	28
17	Coil Screw	ALL	9
18	Nameplate	ALL	44-x
19	N.C. Top Nip	B	115-2
	N.O. Top Nip	BR	115-3
	XP End Plate	B-2 & BR-2	113
20	Coil	ALL	Consult Factory
21	N.C. Coil Cover	B	89
	N.O. Coil Cover	BR	89NO
	N.C. XP Coil Cover	B-2	42NC
	N.O. XP Coil Cover	BR-2	42NO
	XP Bolts	B-2 & BR-2	9-4
	XP Washers	B-2 & BR-2	46-3
23	Coil Housing	B & BR	87
	XP Coil Housing	B-2 & BR-2	41
	C _v Factor	1/4"	1.9
		3/8"	2.8
		1/2"	3.3
		ALL BL's	Adjustable

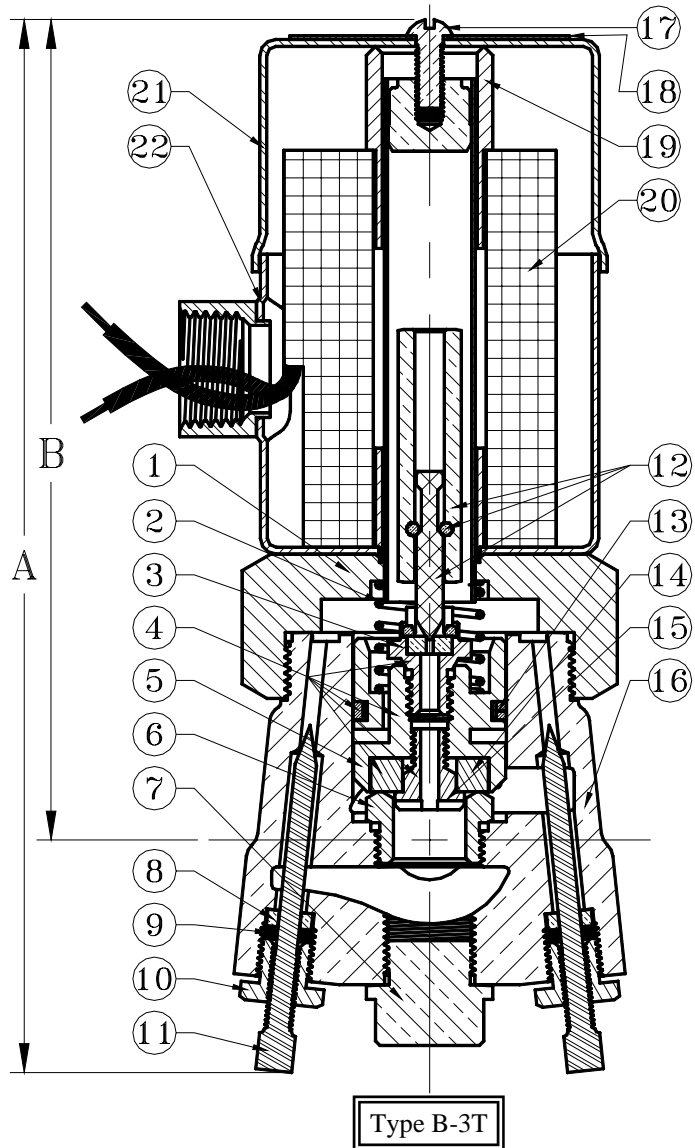

Dimension	B	BR	B-2	BR-2
A	7.3	8.3	7.9	9.0
B	5.7	6.7	6.3	7.4
End to End Length	2.8	2.8	2.8	2.8
Shipping Weight	5 lbs	5 lbs	9 lbs	9 lbs